

**High Load Capacity
Ball Screw Support Bearings**



High Load Capacity Ball Screw Support Bearings

Evolution in injection molding machines has been accompanied by increased demand for higher speed capabilities, longer life, and more compact designs for ball screw support bearings. NACHI's high-load-capacity ball screw support bearings meet this demand.



Features

Greater Axial Load Capacity

Utilizes the largest possible ball diameter within the given boundary dimensions. Additionally, the contact angle has been increased from 50° to 55° to achieve higher dynamic axial load ratings.

Increased Permissible Axial Load

The raceway shoulder diameter and raceway radius have been optimized to increase permissible axial load.

High Axial Rigidity

55° contact angle and optimized preload to achieve high axial rigidity.

Low Torque

Equivalent rotating torque of the previous generation's design was achieved through preload optimization.

Contact Seal Available

Also available with a high-performance grease seal. The seal provides both improved grease retention and contamination prevention. This option provides a maintenance-free design. (The bearing width with the seal is slightly wider than the open type.)

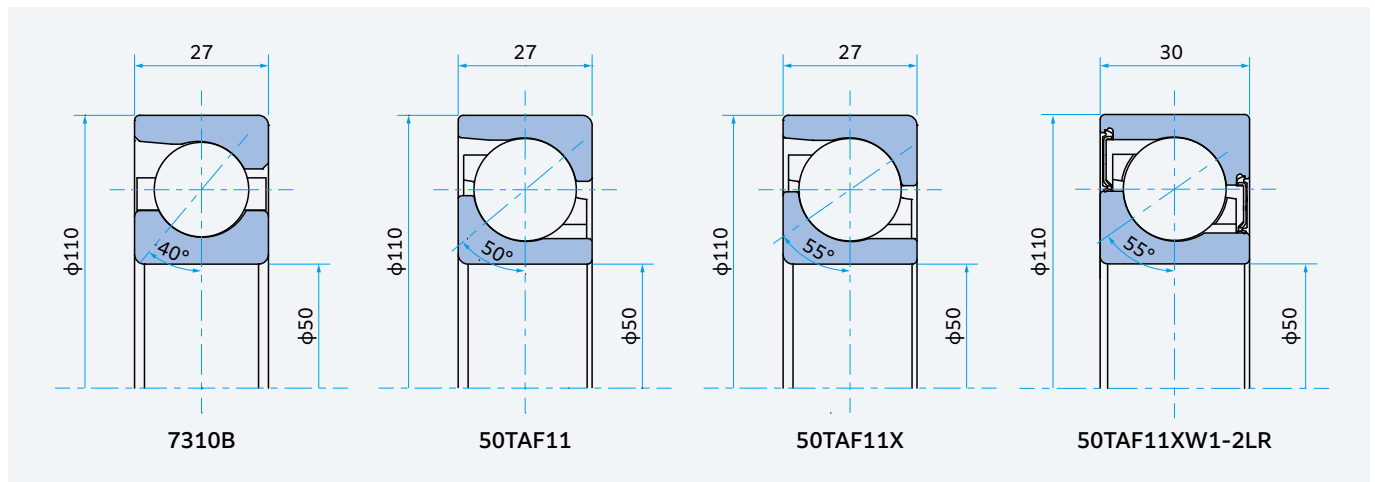

Lineup

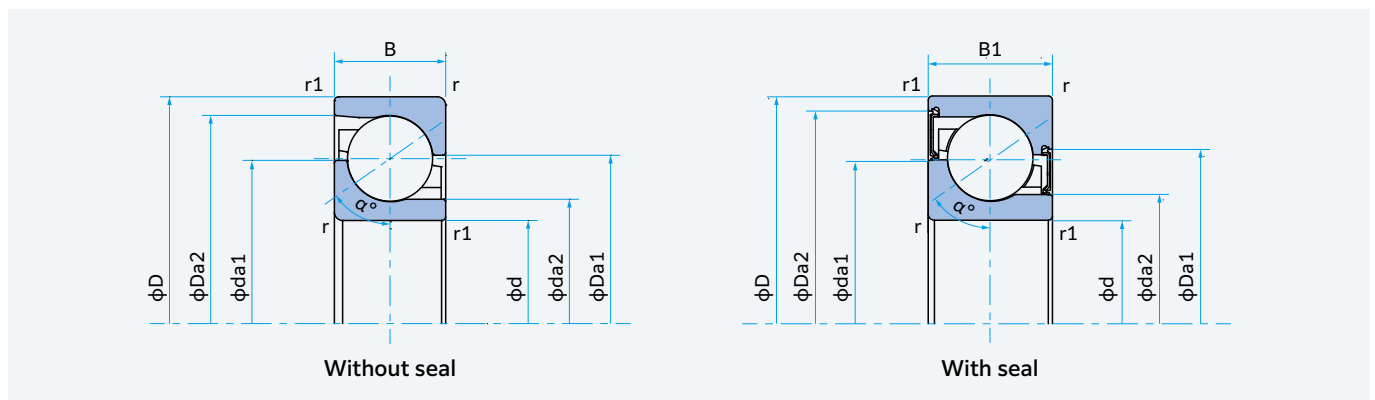

Bearing arrangement

The combination mark (<) is indicated on the outside surface of the outer ring.

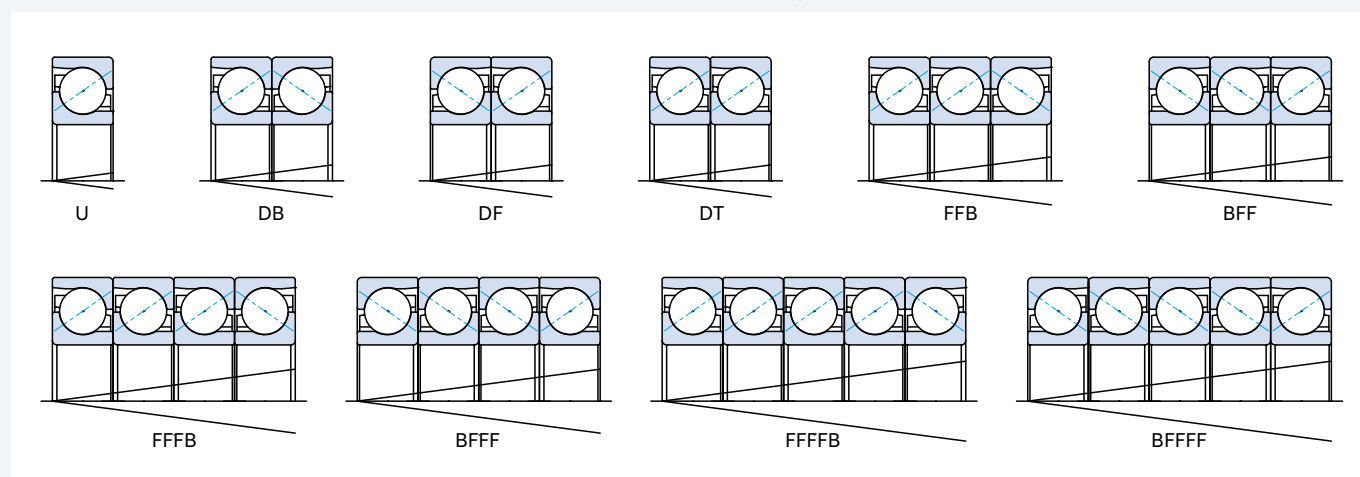

Bearing nomenclature

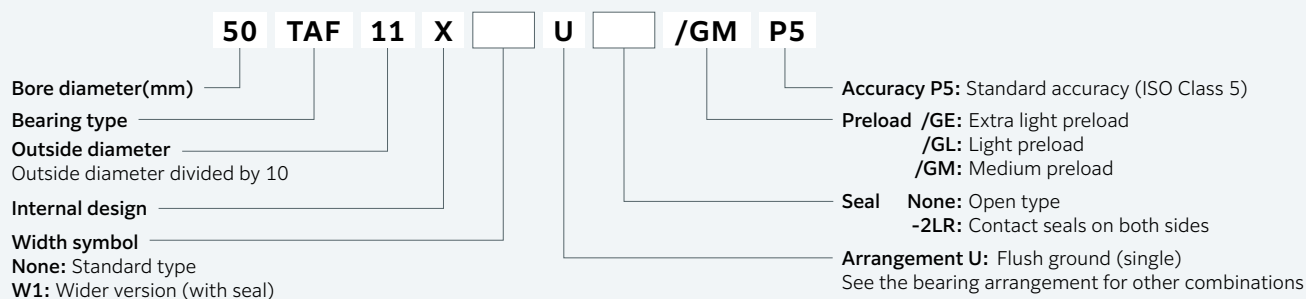

Bearing No.	Boundary dimensions(mm)						Contact angle α	Basic dynamic load rating $C_a^{(1)}$ (N)	Axial limiting load ⁽²⁾ (N)	Limiting speed ⁽³⁾ (grease, rpm)	Boundary dimensions(mm)			
	d	D	B	B1 ⁽⁴⁾	r(min)	r1(min)					da1	da2	Da1	Da2
25TAF05X	25	52	15	-	1.0	0.6	55	47,000	25,700	7,700	38.7	31.6	39.7	48.0
25TAF06X	25	62	17	-	1.1	0.6	55	79,000	40,500	6,800	43.0	32.7	44.5	56.6
30TAF07X	30	72	19	-	1.1	0.6	55	104,000	56,900	5,800	50.4	38.8	52.1	65.8
35TAF09X	35	90	23	-	1.5	1.0	55	145,000	85,500	4,600	64.3	50.8	66.3	82.2
40TAF09X	40	90	23	26	1.5	1.0	55	145,000	85,500	4,600	64.3	50.8	66.3	82.2
40TAF11X	40	110	27	30	2.0	1.0	55	214,000	131,000	3,700	79.2	62.4	81.7	101.0
45TAF10X	45	100	25	28	1.5	1.0	55	171,000	103,000	4,100	71.8	56.9	74.0	91.1
45TAF11X	45	110	27	30	2.0	1.0	55	214,000	131,000	3,700	79.2	62.4	81.7	101.0
50TAF11X	50	110	27	30	2.0	1.0	55	214,000	131,000	3,700	79.2	62.4	81.7	101.0
50TAF13X	50	130	31	34	2.1	1.1	55	275,000	174,000	3,100	94.1	74.7	96.9	119.5
60TAF13X	60	130	31	34	2.1	1.1	55	275,000	174,000	3,100	94.1	74.7	96.9	119.5
60TAF17X	60	170	39	44	2.1	1.1	55	390,000	280,000	2,400	123.8	99.3	127.4	155.8
80TAF17X	80	170	39	44	2.1	1.1	55	390,000	280,000	2,400	123.8	99.3	127.4	155.8
80TAF21X	80	215	47	53	3.0	1.1	55	545,000	405,000	1,900	155.2	125.0	160.5	196.2
100TAF21X	100	215	47	53	3.0	1.1	55	545,000	405,000	1,900	155.2	125.0	160.5	196.2
100TAF26X	100	260	55	62	3.0	1.1	55	670,000	540,000	1,500	187.1	153.4	193.3	234.9
120TAF26X	120	260	55	62	3.0	1.1	55	670,000	540,000	1,500	187.1	153.4	193.3	234.9

Note 1: When the axial load is sustained by 2 rows, 3 rows, or 4 rows, the values in the table for the basic dynamic load rating should be multiplied by 1.62, 2.16, or 2.64, respectively.

Note 2: When the axial load is sustained by 2 rows, 3 rows, or 4 rows, the values in the table for the axial limiting load should be multiplied by 2, 3, or 4, respectively.

Note 3: The limiting speeds are based on standard preload of each bearing.

Note 4: The product lineup of bearings with seals includes those with a bore diameter of 40 mm or higher.

Tolerance table

Inner ring (Unit: 0.001mm)

Nominal bore diameter (mm)		Single plane mean bore diameter deviation		Bore diameter variation in a single radial plane V _{dp}	Mean bore diameter variation V _{dmp}	Deviation of single inner ring width (or outer ring width) ⁽¹⁾ Δ _{BS} (Δ _{CS})		Inner ring width variation V _{BS}	Radial runout of inner ring K _{ia}	Inner ring runout with bore S _d	Inner ring face runout with raceway S _{ia}
		High	Low			High	Low				
Over	Incl.			(Max.)	(Max.)			(Max.)	(Max.)	(Max.)	(Max.)
18	30	0	-6	5	3	0	-120	5	4	8	8
30	50	0	-8	6	4	0	-120	5	5	8	8
50	80	0	-9	7	5	0	-150	6	5	8	8
80	120	0	-10	8	5	0	-200	7	6	9	9

Note 1: Width deviation values are for single bearing. For multiple rows, multiply the applicable value by the number of rows.

Outer ring (Unit: 0.001mm)

Nominal outside diameter (mm)		Single plane mean outside diameter deviation		Outside diameter variation in a single radial plane V _{dp}	Mean outside diameter variation V _{dmp}	Outer ring width deviation V _{CS}	Outer ring radial runout K _{ea}	Variation of bearing outside surface generatrix inclination with face S _D	Outer ring face runout with raceway S _{ea}
		High	Low						
Over	Incl.			(Max.)	(Max.)	(Max.)	(Max.)	(Max.)	(Max.)
50	80	0	-9	7	5	6	8	8	10
80	120	0	-10	8	5	8	10	9	11
120	150	0	-11	8	6	8	11	10	13
150	180	0	-13	10	7	8	13	10	14
180	250	0	-15	11	8	10	15	11	15
250	315	0	-18	14	9	11	18	13	18

Preload and rigidity (Standard preload values and rigidity values are indicated in bold.)

Bearing No.	DB/DF arrangement					
	/GE (extra-light preload)		/GL (light preload)		/GM (medium preload)	
	Preload (N)	Rigidity (N/μm)	Preload (N)	Rigidity (N/μm)	Preload (N)	Rigidity (N/μm)
25TAF05X	80	240	310	385	780	550
25TAF06X	120	255	460	390	1,160	535
30TAF07X	180	345	660	490	1,660	650
35TAF09X	270	410	1,000	495	2,530	870
40TAF09X	270	410	1,000	495	2,530	870
40TAF11X	410	510	1,550	795	3,900	1,080
45TAF10X	320	450	1,200	680	3,050	975
45TAF11X	410	510	1,550	795	3,900	1,080
50TAF11X	410	510	1,550	795	3,900	1,080
50TAF13X	550	600	2,070	920	5,200	1,270
60TAF13X	550	600	2,070	920	5,200	1,270
60TAF17X	890	780	3,350	1,180	8,400	1,580
80TAF17X	890	780	3,350	1,180	8,400	1,580
80TAF21X	1,390	930	5,200	1,030	-	-
100TAF21X	1,390	930	5,200	1,030	-	-
100TAF26X	1,960	1,000	7,500	1,800	-	-
120TAF26X	1,960	1,000	7,500	1,800	-	-

Factors for multiple row arrangements

Number of load sustaining rows	2 rows	3 rows	4 rows
Bearing Arrangement	FFB BBF	FFFB BBBF	FFFFB BBBBF
Preload factor	1.36	1.57	1.72
Axial rigidity	1.49	1.89	2.24

Preload and axial rigidity are calculated by applying the respective factor indicated in the table above.

NACHI

NACHI-FUJIKOSHI CORP.

www.nachi-fujikoshi.co.jp

Tokyo Head Office
Bearing Division

Shiodome Sumitomo Bldg. 17F, 1-9-2 Higashi-Shinbashi, Minato-ku, Tokyo 105-0021
1-1-1 Fujikoshi-Honmachi, Toyama 930-8511

Tel: +81-(0)3-5568-5247
Tel: +81-(0)76-423-5120

Fax: +81-(0)3-5568-5237
Fax: +81-(0)76-493-5231

NACHI AMERICA INC. HEAD QUARTERS
NACHI CANADA INC.
NACHI MEXICANA, S.A. DE C.V.
NACHI BRASIL LTDA.
NACHI EUROPE GmbH
PT.NACHI INDONESIA
NACHI TECHNOLOGY (THAILAND) CO., LTD.
NACHI TECHNOLOGY INDIA PVT. LTD.
NACHI-FUJIKOSHI (CHINA) CO., LTD.

Indiana, U.S.A.
CANADA
MEXICO
BRASIL
GERMANY
INDONESIA
THAILAND
INDIA
CHINA

Tel: +1-317-530-1001
Tel: +1-905-660-0088
Tel: +52-442-153-2424
Tel: +55-11-4793-8800
Tel: +49-(0)2151-65046-0
Tel: +62-(0)21-527-2841
Tel: +66-2-714-0008
Tel: +91-(0)14-9467-1300
Tel: +86-(0)21-6915-2200

Fax: +1-317-530-1011
Fax: +1-905-660-1146
Fax: +52-442-153-2435
Fax: +49-(0)2151-65046-90
Fax: +62-(0)21-527-3029
Fax: +66-2-714-0740
Fax: +91-(0)14-9467-1310
Fax: +86-(0)21-6915-5427

<https://www.nachiamerica.com/>
<https://www.nachi.com.br/>
<https://www.nachi.de/>
<https://www.nachi.co.th/>
<https://www.nachi.com.cn/>

VOC
FREE T&K
Printed with Volatile Organic Compounds.
VOC-Free Ink.

● The specifications are subject to change without prior notice due to improvement.
● Information contained in this catalog protected by copyright, so it is prohibited to copy, reprint, or reproduce in any manner without permission from NACHI.

CATALOG NO. **B3119E-2**

2026.5.X-MD-MIZUNO