

Spot welding robot with built-in cables

SRA133H/SRA166H/SRA210H

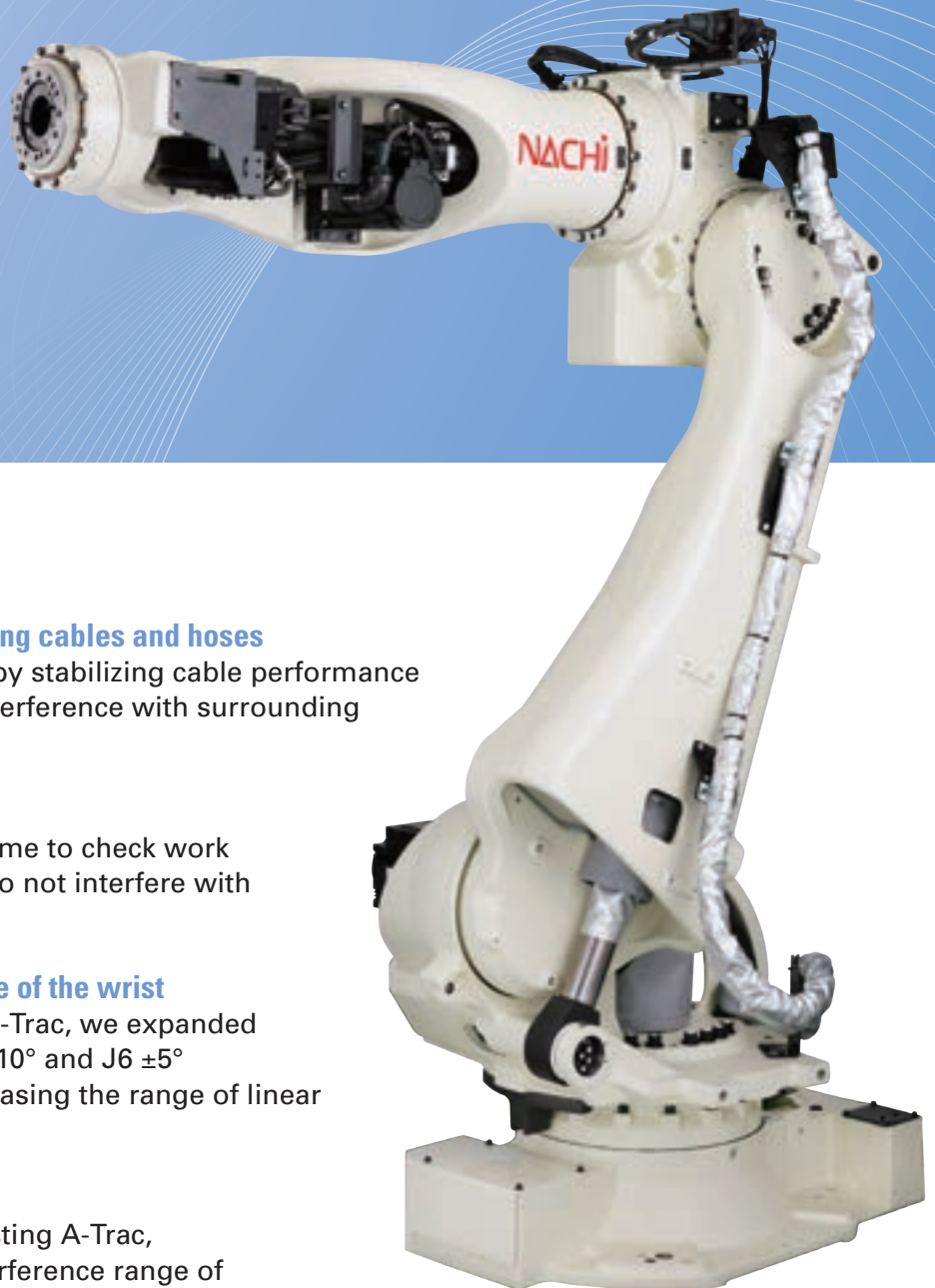

Improved reliability for welding cables and hoses

■ The reliability is improved by stabilizing cable performance to avoid damage due to interference with surrounding equipment.

Shortened the startup time

■ We greatly decreased the time to check work programs because cables do not interfere with surrounding equipment.

Expanded the operating range of the wrist

■ Compared to the existing A-Trac, we expanded the operating range of $J5 \pm 10^\circ$ and $J6 \pm 5^\circ$ (payload class 210kg), increasing the range of linear movement 20%.

Improved accessibility

■ When compared to the existing A-Trac, we have decreased the interference range of the wrist 27%, making access to narrow places possible.

Speed

■ The hollow arm can also operate at the same high speeds as the SRA.

SRA133H/SRA166H/SRA210H

Robot specifications

| Item | | Specifications | | | |
|-----------------------------------------------------|-----------------------|--------------------------------------------------------------------------------------------------------------------------------------------------------|----------------------|----------------------|--|
| Robot model | | SRA133H-01 | SRA166H-01 | SRA210H-01 | |
| Structure | | Articulated | | | |
| Number of axes | | 6 | | | |
| Drive system | | AC servo system | | | |
| Max. operating envelope | J1 | ±3.14rad (±180°) | | | |
| | J2 | -1.40~+1.05rad (-80~+60°) | | | |
| | J3 | -2.56~+2.62rad (-146.5~+150°) | | | |
| | J4 | ±3.66rad (±210°) | | | |
| | J5 | ±2.18rad (±125°) | | | |
| | J6 | ±3.66rad (±210°) | | | |
| Max. velocity | J1 | 2.09rad/s (120°/s) | 2.01rad/s (115°/s) | | |
| | J2 | 1.92rad/s (110°/s) | 1.83rad/s (105°/s) | | |
| | J3 | 2.06rad/s (118°/s) | 2.00rad/s (115°/s) | 1.97rad/s (113°/s) | |
| | J4 | 3.66rad/s (210°/s) | 3.05rad/s (175°/s) | 2.27rad/s (130°/s) | |
| | J5 | 3.05rad/s (175°/s) | 2.98rad/s (171°/s) | 2.27rad/s (130°/s) | |
| | J6 | 5.41rad/s (310°/s) | 4.88rad/s (280°/s) | 3.58rad/s (205°/s) | |
| Payload | Wrist | 133kg | 166kg | 210kg | |
| | Forearm ^{*1} | 20kg | | | |
| Allowable static load torque for wrist | J4 | 830N·m | 960N·m | 1337N·m | |
| | J5 | 830N·m | 960N·m | 1337N·m | |
| | J6 | 441N·m | 520N·m | 720N·m | |
| Allowable moment of inertia for wrist ^{*2} | J4 | 85kg·m ² | 100kg·m ² | 200kg·m ² | |
| | J5 | 85kg·m ² | 100kg·m ² | 200kg·m ² | |
| | J6 | 45kg·m ² | 50kg·m ² | 155kg·m ² | |
| Position repeatability ^{*3} | | ±0.1mm | | ±0.15mm | |
| Installation | | Floor | | | |
| Ambient conditions | | Ambient temperature: 0~45°C ^{*4} Ambient humidity: 20~85%RH (without condensation) Vibration: Not more than 0.5G (4.9m/s ²) | | | |
| Noise level ^{*5} | | 79.6dB | | | |
| Robot mass | | 1040kg | 1100kg | | |

1 [rad] = 180/π[°], 1 [N·m] = 1/9.8 [kgf·m]

*1: This value changes by placement and load conditions of a wrist.

*2: The Allowable moment of inertia of a wrist changes with load conditions of a wrist.

*3: This value conforms to "JIS B 8432".

*4: Permitted height is not higher than 1,000m above sea level. If used in higher place, permitted temperature is affected by height.

*5: A-weighted equivalent sound level measured according to JIS Z 8737-1 (ISO 11201). (while operating at maximum speed with rated load)

Exterior dimensions and operating envelope

SRA133H-01/SRA166H-01/SRA210H-01

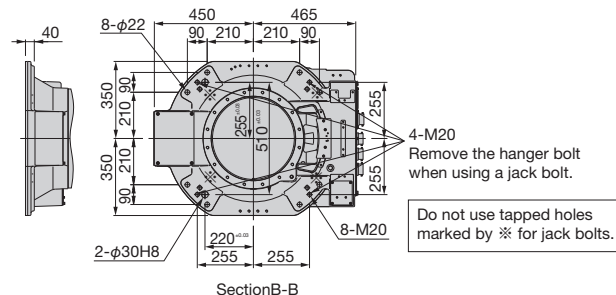
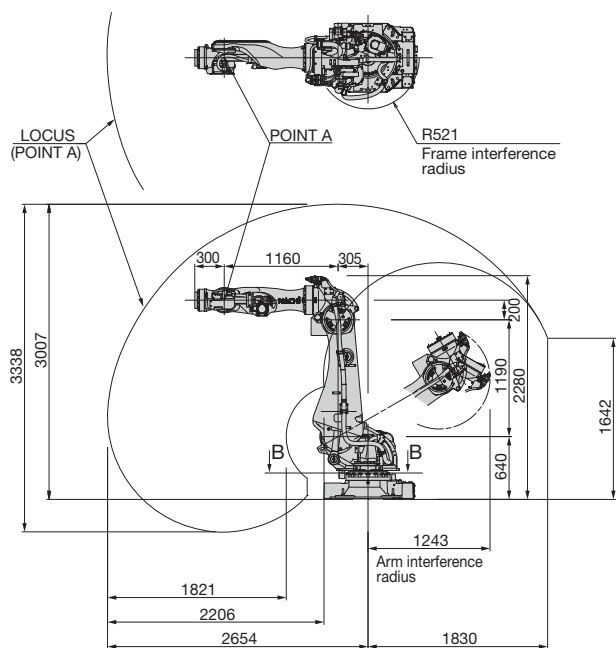

SRA133H-01

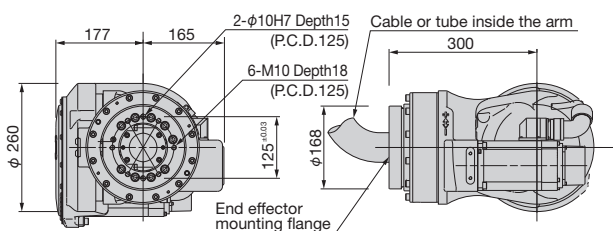

SRA166H-01/SRA210H-01

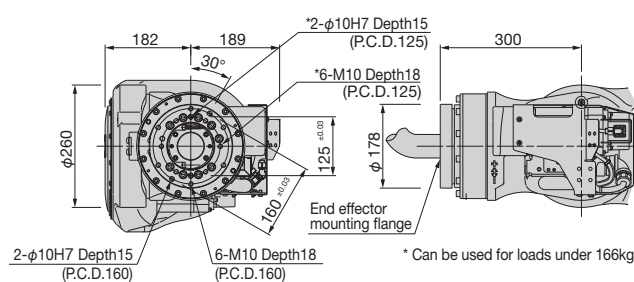

● The specifications are subject to changes without notice.

● In case that an end user uses this product for military purpose or production of weapon, this product may be liable for the subject of export restriction stipulated in the Foreign Exchange and Foreign Trade Act. Please go through careful investigation and necessary formalities for export.

NACHI-FUJIKOSHI CORP.

Tokyo Head Office

Shiodome Sumitomo Bldg. 17F 1-9-2 Higashi-shinbashi, Minato-ku, Tokyo 105-0021, JAPAN

Tel: +81-(0)3-5568-5245 Fax: +81-(0)3-5568-5236

Toyama Head Office

1-1-1 Fujikoshi-Honmachi, Toyama 930-8511, JAPAN

Tel: +81-(0)76-423-5111 Fax: +81-(0)76-493-5211

NACHI ROBOTIC SYSTEMS INC.

42775 West 9 Mile Road Novi, Michigan, 48375, U.S.A.

Tel: +1-248-305-6545 Fax: +1-248-305-6542

URL: <http://www.nachirobotics.com/>

E-mail: marketing@nachirobotics.com

NACHI BRASIL LTDA.

Avenida João XXIII, No.2330, Jardim São Pedro, Mogi das Cruzes, S.P., CEP 08830-000, BRASIL

Tel: +55-11-4793-8813

URL: <http://www.nachi.com.br/>

NACHI EUROPE GmbH

Bischofstrasse 99, 47809, Krefeld, GERMANY

Tel: +49-(0)2151-65046-0 Fax: +49-(0)2151-65046-90

URL: <http://www.nachirobotics.eu/>

NACHI TECHNOLOGY (THAILAND) CO., LTD.

BANGKOK SALES OFFICE

Unit 23/109(A), Fl.24th Sorachai Bldg., Sukhumvit 63 Road(Ekamai), Klongtonnua, Wattana, Bangkok 10110, THAILAND

Tel: +66-2-714-0008 Fax: +66-2-714-0740

PT.NACHI INDONESIA

TEMPO PAVILION I, 7FL JL. HR Rasuna Said Kav. 10-11

Seliabudi Jakarta Selatan DKI Jakarta -12950, INDONESIA

Tel: +62-021-527-2841 Fax: +62-021-527-3029

NACHI KG TECHNOLOGY INDIA PVT.

GURGAON HEAD OFFICE

Unit No.207, 2nd Floor, Sewa Corporate Park, MG Road, Iffco Chowk, Gurgaon 122001, Haryana, INDIA

Tel: +91-(0)12-4450-2900 Fax: +91-(0)12-4450-9210

CATALOG NO. R7205E

2015.10.V-ABE-ABE